

CE DL868-IN-B

# RADIOMODEM UHF

DL868-IN CE

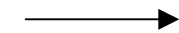

RS 232-RS 485  
INTERFACE +  
1 INPUT , 1 OUTP.  
GALVANICALLY  
ISOLATED



All stated specifications are subjected to change without notice or obligation.

## General Informations:

**DL868-IN-B** is a UHF simplex/half-duplex high quality radiomodem with an output power of **25 mW<sub>ERP</sub>** in the band **868/868.6 MHz and 868.7/869.2 MHz** and **25/150/500 mW SW** defined in the band **869.4/869.65 MHz** with a dedicated  $\lambda/4$  antenna, mod. ANT868L, or a **vertical dipole** ANT868DV, operating **12,5 or 25 kHz** canalisation, step **12.5 kHz** in according to the ERC Recommendation **70-03**. These products are characterised by **FREE USE**. The radiomodem is enclosed in an extruded aluminium box containing the RS232/RS485 interface and supply unit card RMO148.

**DL868H-IN** defines the same device without the box while **DL868H** is the basic unit without the **RS232/485** interface and supply. In this case a direct TTL interfacing is required and it represents the more favourable solution for a direct microcontroller connection. The following models **DL868H-IN-B-Y6**, **DL868H-IN-Y6** and **DL868H-Y6** are the same devices equipped with a **six elements Yagi antenna** ANT868Y6.

All the Radiomodems are fully transparent to the user and configurable from the PC by dedicated software for the desired functions.

### Features:

- **Store & Forward** mode with **448 Bytes** maximum **Buffer size**
- **ON/OFF switching** controlled via **DTR criteria**
- **Low power consumption** in both **RX and TX** mode with selectable **Power Saving mode** from configuration software
- **Broadcasting Mode** or **Address management** through configuration software or directly from DTE
- **Digital Repeater (digipeater) Mode** to permit communications between two or more hidden stations
- **Remote programming** of the devices and channel selection from DTE
- **More sophisticated features** as : **ACK** and repetition of the not received messages, address reversing for the answer, **ECHO**, **NAK** to DTE at the end of repetitions, address to DTE and so on.

These devices, assembled with **SMT** components **in the industrial temperature range**, is particularly suitable for **Low-Cost** radio networks in which the **battery or solar cells** supply require a low power consumption together an high quality product.

General		Transmitter	
Operating band	868-868.6 , 868.7-869.2 , 869.4-869.65 MHz	Output Power	25-150-500 mW auto setting
Channel number	12.5 kHz step	Frequency deviation	± 1.8 kHz @ 12.5 kHz ± 3 kHz @ 25 kHz
Canalisation	12.5 or 25 kHz	Output power stability	±1.5 dB
Modulation	9K00F1D or 18K0F1D	Adjacent channel power	EN 300 220 v2.3.1
Radio data rate (Tx / Rx)	4800 @ 12.5 kHz , 9,600 @ 25 kHz	Ch. adjacent transitory power	EN 300 220 v2.3.1
Frequency stability	±1 ppm from -30to 70 °C	<b>Receiver – Class 2 - LBT and Agility</b>	
Supply voltage	8 → 36 Vdc with limited source power	Sensitivity @ BER< 10 <sup>-2</sup>	<-107 dBm @ 25 kHz
Rx consumption	~ 30 mA @ 12 Vdc – RS232/485 Relay OFF	Attenuation on adjacent channel	EN 300 220 v2.3.1
Tx consumption	~ 75 mA ( about 500 mA @ 500 mW )	Blocking	EN 300 220 v2.3.1
Consumption DTR OFF	< 1 mA	<b>Interface</b>	RS 232 e RS 485
Antenna	$\lambda/4$ - $\lambda/2$ or 6 elements Yagi	Data rate (Interface)	1,200 to 38,400 bps
Dimension H x W x D	100 x 90 x 40 mm ( 3.94 x 3.54 x 1.58 inches)	Data format (standard)	Asynchronous 8,N,1- 8,E,1-8,O,1
Operative temperature	-30 → +70 °C ( -22 → 158 °F)	Operative modality	Simplex or half-duplex
Reference Directives	EN 300 220-1 v2.3.1		
Out switch aux	N.O. 28 Vac @ 0,5 A or 60 Vdc @ 1 A		
Digital input	5 → 24 Vdc or 3.50 → 20 Vac. Zinp: 2.2 kΩ		

**ERE snc** Via Ermanno Ge 9/11 27049 Stradella (PV) – Italy – Tel. 0385-48139 Fax 0385-40288

**E-mail: info@ere-online.it**

## DL868H-IN-B – The circuit

Radiomodems **DL868H-IN-B** and its open version **DL868H-IN** are built by the interface and supply card **RMO148** and the radiomodem module **DL868H**.

The **RMO148** card realises the following functions:

- **Power supply conditioning.** A step-down switching regulator give a stabilised voltage of 5 Vdc from an input voltage between 8 to 36 Vdc. It feeds directly the RS232/RS485 interfaces and, through a drop diode, the RF power amplifier. A 3.3 Vdc linear regulator is used for the DL868H module.
- **Optoisolated input** for digital input requires a DC input from 5 to 24 V or AC input from 3.5 to 20 V. The input impedance is of 2.2 k $\Omega$ , resistive.
- **Relay Output**, normally **Open**, can manage a 28Vac 0.5 A current or 60Vdc 1 A current
- **RS232** and **RS485** interfaces both on the **D-shell female connector**. The interface selection is achieved by configuration software trough electronic switch. As shown in the following Fig. 1 the RS 232 interfaces utilises the connector pins from 2 to 8 while the RS 485 utilises the pins Nos. 1 and 9.
- **Radiomodem status** with a bi-colour LED normally **green**. The data flow into or out the unit causes the color **change** (from **green** to **orange**) of this LED. During the configuration process this Led is **orange**. A second **Red** Led is turned on during the transmission.
- **Antenna connection** with a **BNC female connector**.

**DL868H MODULE** – The DL868H Radiomodem used in this application is programmed with a specific firmware version using the RTXEN, CONFIG, CH0, CH1, CH2 criteria to manage respectively:

- **Optoisolated Input**
- **Output DATA Led**
- **Relay output**
- **RS 232 enable**
- **RS 485 enable**

The remaining criteria retain the original features. Detailed information on the module are available on the DL868 manual.

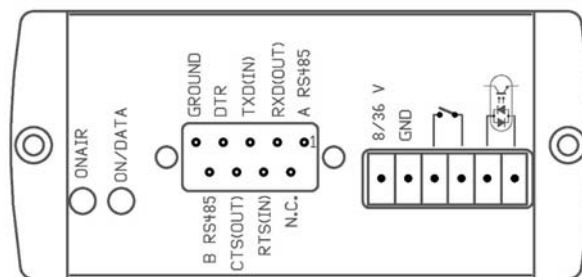

FIG. 1

The equipment is FREE USE for telemetry & command, AMR, tracing and tracking of goods and so on

Regulatory standards: EN 300 220-1 v2.3.1 EN 60950-1: 2001+All A11 2004 ,  
EN 301 489-1/3

## Products and ancillary :

- a) **DL868H-IN**.....Radiomodem with RS232 and RS485 interfaces without box (open card version): available with antenna  $\lambda/4$  **ANT868L** or vertical dipole **ANT868DV**
- b) **DL868H-IN-B**.....Radiomodem with RS232 and RS485 interfaces included in an extruded Aluminium box: available with antenna  $\lambda/4$  **ANT868L** or vertical dipole **ANT868DV**
- c) **DL868H-IN-Y6**.....Radiomodem with RS232 and RS485 interfaces without box (open card version): available with 6 elements Yagi antenna **ANT868Y6 + 10 mt. coaxial cable RG58U**
- d) **DL868H-IN-B-Y6**.....Radiomodem with RS232 and RS485 interfaces included in an extruded Aluminium box: available with 6 elements Yagi antenna **ANT868Y6 + 10 mt. coaxial cable RG58U**
- g) **DRP-03**.....Connection for guide DIN in extruded Aluminium

### NOTE ON POWER SUPPLY

The Radiomodem DL868H or DL868H-IN-B should be fed with a power limited voltage source between 8 and 36 Vdc and is not required a stabilisation due to the presence of an internal efficient stabiliser. The power supply is protected against polarity reversing and is protected by a 750 mA internal SMT fuse. The current drawn depends on the power supply voltage and reaches it's maximum value during the transmission with the minimum supply voltage. A value of **500 mA** ( for **500 mW** outp. ) may be used to choose an adequate supply unit.

### ANTENNA: SELECTION AND CONNECTION

#### Indoor use:

- 1) Use the  $\lambda/4$  models ANT868L/BNC with BNC male connector to be inserted directly in the antenna output of the Radiomodem. If the Radiomodem is supported on a plan, provide a right angle adapter BNC M / F to keep the antenna vertical.
- 2) The Radiomodem can be inserted into a plastic or metal box (preferably). Provide a 13 mm hole to fix the panel TNC female connector of an extension cable BNC/M - TNC/F and plug the BNC male on the Radiomodem antenna connector.
- 3) Improved efficiency may be obtained using the vertical dipole antenna ANT868DV. This is supplied with 5 meters of low loss coaxial cable and don't requires the ground plane so may be installed in the most favourable mode.

#### Outdoor use:

For external applications the Radiomodem need to be inserted into suitable containers for IP67 protection or better. These solutions can be used:

- 1) Close the Radiomodem in a plastic or, better, metal container. Provide a 13 mm hole to fix the panel TNC female connector of an extension cable BNC / M-TNC / F and plug the BNC male on the Radiomodem antenna connector. Take care to assure an efficient electric contact between the ground of the panel TNC female connector and the metallic box. If the container is of an insulating material, the absence of the ground plane for the  $\lambda/4$  antennas decreases the radiation efficiency. To minimise this decreasing in efficiency a metal strip or a wide wire placed in the internal side of the box and electrically connected to the TNC ground, simulates the ground plane and allows the utilisation of the  $\lambda/4$  antennas ANT868L/TNC . For maximum efficiency in this case the vertical dipole ANT868DV is recommended.
- 2) The Radiomodem will be contained in a plastic or metal box with IP67 protection or better. Provide the required holes on the bottom side of the box to fix the wall-pass cable for both antenna and supply/serial line cables. It's possible to use the vertical dipole antenna ANT868DV or, in the Y6 suffix versions, the 6 elements Yagi antenna ANT868Y6 + 10 mt, of coaxial cable RG58U, to perform both the directivity feature and gain of 3 – 4 dB, keeping the maximum transmitted ERP power within 500 mW.

**The equipment is FREE USE for telemetry & command, AMR, tracing and tracking of goods and so on**

**Regulatory standards: EN 300 220-1 v2.3.1 , EN 60950-1: 2001+All A11 2004 ,  
EN 301 489-1/3**

**ERE snc** Via Ermanno Ge 9/11 27049 Stradella (PV) – Italy – Tel. 0385-48139 Fax 0385-40288  
**E-mail: info@ere-online.it**

## Starting use:

The **DL868H-IN-B** device is delivered with the following **default configuration**:

- ◆ **Channel radio 869412.5 kHz in broadcasting mode**, transparent to the user.
- ◆ **9,600 bps UART Data Rate, 8,N,1 format, No Flow Control and 448 Bytes Buffer size**
- ◆ **9600 bps Radio Data Rate with 25 kHz canalisation** , steps 12.5 kHz
- ◆ **RF Output Power 150 mW<sub>RMS</sub>**

The device, if a special configuration is not demanded, can be immediately connected to a serial port RS232 or RS485 of an apt DTE (PC, PLC, RTU, etc)

The device configuration may be done by the **Configuration Software DL148SW-IN**, also available for free download from our website, and the internal **Help** shows all the necessary information on the software utilisation and configuration parameters.

Two conditions may be chosen during the configuration process:

Detailed information about the device protocol are available in the **DL148PRO-IN** file , available, as the previous, from our website.

## Special functions:

**LBT – Listen Before Talk** – If enabled, before the transmission of a packet, the radiomodem checks the status of the operating channel by a period of 5 milliseconds and ,only if the channel is free for all this period, the transmission start. The free/busy threshold is set to –100 dBm in according to the European directives. If during the checking period the channel status changes from free to busy condition, the radiomodem reset the procedure and it restart when the channel come back to free condition. The incoming data to transmit is stored in the internal buffer until the radiomodem can transmit it, so the Flow Control option must be enabled to stop the next incoming data from DTE.

**AFA – Adaptive Frequency Agility** – In the configuration process is possible to select 1, 2 or 3 channels as above specified. When more than 1 channel is selected the AFA mode automatically starts, so the radiomodem scans the selected channel and transmit on the less interfered one. If also LBT is enabled, the LBT thresholds are used to define the free channel and the unit transmit on this one.

Using the LBT and AFA the **Duty Cycle limits** of the European directives **can be exceeded**.

Of course, if these functions are selected, **all** the units in the communication network **must be configured** with these functions to allow the communication process because the improvement of the reliability of the communication is obtained lengthening the preamble time. If normally the preamble times are 5.83 milliseconds for 9600 b/s they become of 20.75 milliseconds for two channels and of 30.71 milliseconds for three channels.

**DUTY CYCLE**: If it is not used the LBT+AFA function the Duty cycle mediated on the hour must be respected (10% metering & commands, 1% tracking and tracing).

**PWSAVING** - The **Power Saving** function allows a considerable energy saving in all situation where the device is feed by a battery or solar cells and, of course, this saving is obtained lengthening the transmitting periods. This may have the appearance of a nonsense, but the maximum amount of energy is spent in the receiving status because the transmitting mode is normally shorter than the receiving one. In the Power Saving mode the **ON** time of the unit is internally set to **10 milliseconds** for 18.75 kHz of canalisation, while the **OFF** time can be set in configuration in **10 milliseconds** step. The **preamble time length is increased** by the selected **PwSavOFF** time and, of course, this time **must be the same** in **all units** of the communication network. An incoming preamble from radio and/or an incoming data on the serial port exits the unit from the Power Saving condition and it stays in the normal operative condition until the selected **PWSava time** is expired. During the **PWSava** time the radiomodem utilises a normal length preamble so the answer can be transmitted in the allowable shortest time.

The **PWSava time** can be selected in the **100 milliseconds to 25,400 millisecond** range. The value **PWSava = 255** keeps the unit **always operating** but the generated preambles have a length defined by the selected **PwSavOFF** time. This feature may be useful when the Master unit and the digipeaters, if presents, are supplied by the Main to allow the decoding of both short or long preambles. The PWSava time can modify the total amount of supplied energy, so its correct choice is fundamental for the better results. For detailed information please refer to the Configuration Software Help an the protocol description.

**Att.!! The user can use a maximum time of PWSAVOFF such that : ( T\_PwsavOff + T\_PwsavOn + T\_Data < 1 sec. One second represents the maximum continuous time of transmission granted from normative EN 300 220-1.**

## DL868 -IN-B - CONFIGURATION

The Radiomodem setup is achieved by the **Configuration Software DL148SW-IN** dedicated to **all** devices. This software is releasable from our Internet website at URL: [www.ere-online.it](http://www.ere-online.it)

Follow the configuration procedure:

- 1 - Install the configuration software on your Personal computer. The required OS are Windows '95 → XP and the PC **must have** a RS-232 Port.
- 2 - Connect the radiomodem RS-232 port to the computer COM port with a **straight cable (NO Null Modem)**.
- 3 - Start the software, open the **Option menu** to select the **COM Port** and the **operating Band** of the radiomodem in according to the owned model.
- 4 - Power On the radio modem and click on the button **'Turn ON'** in the configurator. The system go into configuration mode indicated by the ON/DATA LED color change from green to orange.
- 5 - Follow the online help of the configuration software to achieve the complete radiomodem setup.
- 6 - The configuration parameters can be saved in a file for subsequent use or control.
- 7 - After the configuration process quit the setup procedure by clicking on the button **'Turn OFF'** in the configurator or by removing the power.

The configuration software shows three pages: **BASIC, ADVANCED** and **LINK TEST** for the communication test after the setup.

### **BASIC:**

**SYSTEM CODE** – It defines univocally the radio network. Of course **all** radiomodems of the network **must have** the **same System code**.

**RX and TX Frequency** -The receiving and transmitting frequency. The frequency values are indicated in **kHz**. The channel is selected clicking on the related box. If two or maximum three channels are selected, the **Adaptive Frequency Agility** function is introduced to choose the less disturbed channel.

**RTC upd** – If selected, allows the send of the **Real Time Clock data** in the packet. A feature for specific application, **not available** in the standard units.

**LBT – Listen Before Talk** . Before transmitting the module measure disturbing signal on the radio channel and start the transmission only if it is lower than a threshold value of- 100 dBm with 25 kHz canalisation or -103 with 12.5 kHz canalisation.

**BROAD** - If selected, **all radiomodem release the received packet**. The **target address** is not considered but **necessary** to allow the usage as **digipeater** and the **remote configuration**, if requested. Of course the **Its address** must be different for each radiomodem. If the Broad option is unselected **only the addressed modem release the packet** to the DTE. The utilised addresses may be set in configuration (see Advanced page) or given by DTE if **Addr from DTE** is chosen; in this case the address precede the sending message. Please see the Addr from DTE paragraph for more information.

**POWER** – RF power output. An **H (High)**, **M (Medium)** or **L (Low)** power level choice is available clicking on the box.

**FLOW CONTROL** – In **RS-232** mode controls, via the **CTS criteria**, the buffer loading. If selected, the buffer dimension is **slightly lower** than **448 byte**. Do not select for message of 448 bytes length or for **RS-485** mode.

**RS485** – choose between **RS232** or **RS485** interface.

**TIME DTX** – Configure the delay time between the end of the last character of the incoming data and the start of the transmission cycle. If the DTE inserts a (variable) delay time between the bytes of a packet, the appropriate choice of this time avoids the cutting off of the message. An example of this phenomenon can be seen using Hyperterminal to send a packet. If Flow Control is used this time is **not considered**.

**BAUD RATE DTE** – Set the **RS-232** or the **RS-485** serial port speed. The possible speed range is from 1,200 bps to 38,400 bps. Parity selection clicking the desired box.

**DIG IN REPET. TIME** – Defines the time between successive transmission of the digital input state. Its range from **0, disabled**, to **60 minutes**.

**ERE snc** Via Ermanno Ge 9/11 27049 Stradella (PV) – Italy – Tel. 0385-48139 Fax 0385-40288  
**E-mail: info@ere-online.it**

## DL868-IN-B - CONFIGURATION

### ADVANCED :

**ITS ADDRESS** – Address of the radiomodem unit. Allowable values between **1** and **255**. The address defines univocally each radiomodem. The value **1** in a unit of a Point-Multipoint network operating in **Power Saving Mode** denotes the **always powered Master Unit**.

**TARGET** – Address of the destination unit. Allowable values from **1** to **255**. In all operating conditions this value **must be set** to permit the unit identification. In **Broadcasting** and **Addr from DTE** modes, although the address is not used, it must be present.

**DIGIP.** – Address of the unit used as **repeater**. Allowable values from **1** to **255**. If the value is **0** no repeater is used. The digipeater may be a peripheral unit. In **Broadcasting mode** it first repeats the message afterwards send repeated data to the serial port. In all operating modes with addresses the digipeater unit repeats the message without sending data to the serial port. In the **Address from DTE** mode this field is not used and the correct addressing must be assigned from DTE.

**ACK** – Selecting this option the target radiomodem when receive a valid packet answers to the source modem with an **ACK packet**. If the source modem don't receive the ACK, it continues to repeat the message until the receiving of an ACK. The option is available only for all addressed modes but **not for Broadcasting or ECHO** mode. The acknowledge packet passes through the digipeaters units without repetitions.

**REPETITION** – Set the numbers of the message repetitions when ACK is selected. Allowable values from 1 to 255.

**NAK TO DTE** – Selecting this options the radiomodem sends a **NAK** character (ASCII 21=§ ) to the DTE when all the re-transmissions have been unsuccessful.

**ADDR TO DTE** – If selected , the receiving radiomodem sends the source unit address to the DTE. The address byte precedes the received data.

**RX ADDR FOR TX** – If selected, the receiving radiomodem holds in memory all the incoming addresses and uses them in the **reversed order** for the answer. An useful option for applications with “not intelligent” DTEs.

**ECHO** – If selected, the packet sent to the target radiomodem is re-transmitted to source radiomodem without releasing it to the serial port. It's an utility to check the radio link. This option is not available in **Broadcasting mode**.

**ADDR FROM DTE** – Available only if **Rx Addr for Tx** function is **inactive**. If selected it is a duty of DTE provide to the correct addressing of each packet. The addressing is made by some additional bytes preceding the message in the following order:

**One System Code Byte [1..255]**

**One Flag byte** with the bit having the following scope:

**bit 0 (LSB) = Broadcasting, bit 1 = ECHO, bit 2 = ACK request**, all other bits to MSB set to **0**

**One Unit Number Byte [1..9]** which contains both target and all the digipeaters if present

A maximum of **8 Digipeaters Addresses Bytes** in the correct sequence of use

**One Target Address Byte** and then the message to be send (maximum 448 bytes).

**PWSAVOFF** – It is the **Power OFF** time in the **Power Saving** cycle. This time is set with **steps of 10 milliseconds** and the allowed values vary from **0** to **240**. Setting this time to **0** the power saving is **inactive** and the unit is **always** operative. Of course **all units** in the network **must be set with the same PWSAVOFF time** to allow the communication because it is used to calculate the **preamble length**. The **Power ON** time is internally set to **10 msec. for CH 18.75 kHz**. The maximum setting power off time may be of **2.40 seconds** .

**Attention! The EN 300 220 directive imposes a maximum transmission time of 1 second.**

**PWSAVA** – Define the waiting time before starting the Power Saving cycle after any operation. This time **must be the same for any unit** in the network. Maximum settable value is **254** while **255** is a reserved value that **define unit as the Master** of a point multi-point network where the master is continuously turned-on but the preamble length is defined by the PwsavOff time.

**Channel change from DTE:** the change of the channel between the (six or three) configured channels can be made through a specific frame sent by the DTE, the feature is enabled **only if Addr from DTE is active**.

**Send 3 Bytes (only 3)** in the sequence: **00h - 10h - 'New\_Channel\_Number'**, where the values of 'New\_Channel\_Number' (from **1** to **3** or **6**) represent the **equivalent configured channels (see table)**. A value of **0** in the 'New\_Channel\_Number' or a Radiomodem **reset restores the Configuration selection**. After any channel change command it's essential to **wait at least 2 milliseconds** before proceeding with normal activity.

**In Broadcasting Mode**, due to the Addr from DTE enabled option, the DTE must precedes each data frame sent to the Master radiomodem by the following four bytes: **System Code - 01h - 01h - 01h**.

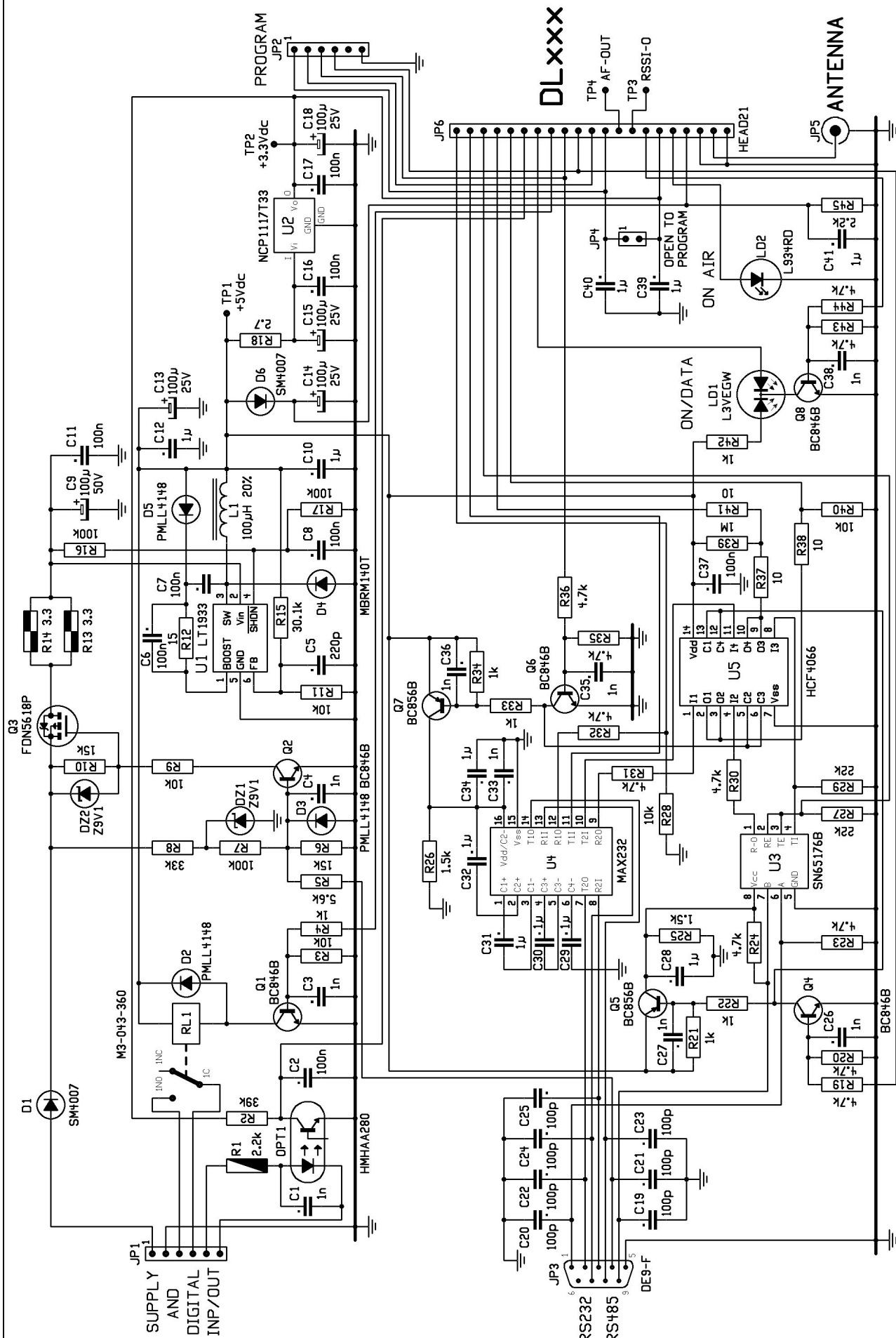

# DLXXX

E.R.E. S.n.c. Italy  
 Via Ermanno Ge, 9/11 27049 Stradella (PV)  
 Title: RMD148: Electric diagram.  
 Size: Document Number: RMD148.SCH Rev.: 2.1  
 Date: February 25, 2009 Sheet 1 of 1

**RESISTORS**  
 CARBON OR METAL FILM  
 1/10W 1/4W 1/2W CERAMIC OR CERAMIC MULTILAYER ELECTROLYTIC POLARIZED

**CAPACITORS**  
 ALL ELECTROLYTIC CAPACITOR ARE :20% TOLERANCE.  
 C>10p: : 5% (NP0 AND X7R TYPES) ; :10% (X5R TYPE)  
 CERAMIC CAPACITORS: C<10p: :0.25pF (NP0 TYPE)  
 ALL RESISTORS ARE :1% UNLESS OTHERWISE SPECIFIED.

TOLERANCES:  
 ALL RESISTORS ARE :1% UNLESS OTHERWISE SPECIFIED.  
 CERAMIC CAPACITORS: C<10p: :0.25pF (NP0 TYPE)  
 ALL ELECTROLYTIC CAPACITOR ARE :20% TOLERANCE.

